

**JVC**



Show Your True Colours.

EN

LCD Monitor

**GD-32X1U**

**INSTRUCTIONS**

LCD Monitor ◆ INSTRUCTIONS

LCT2576-001A-H

# JVC

**HDMI**™  
HIGH-DEFINITION MULTIMEDIA INTERFACE

LCD Monitor

# GD-32X1U

32" class (31.5" Diagonal)



ENGLISH

## INSTRUCTIONS



As an "ENERGY STAR®" partner, JVC has determined that this product or product model meets the "ENERGY STAR®" guidelines for energy efficiency.

Please read the important notice for energy efficiency on page 49.

### **Important Note:**

In the spaces below, enter the model and serial number of your monitor (located at the rear of the cabinet). Staple your sales receipt or invoice to the inside cover of this guide. Keep this user's guide in a convenient place for future reference. Keep the carton and original packaging for future use.

Serial Number: \_\_\_\_\_

Model Number: \_\_\_\_\_

# Warnings

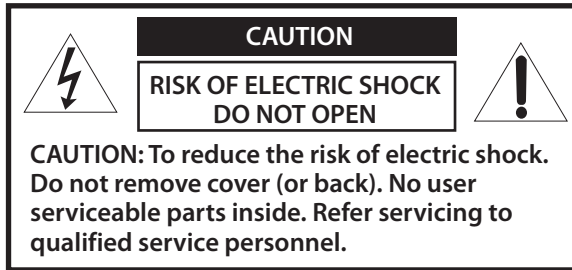

The lightning flash with arrowhead symbol, within an equilateral triangle is intended to alert the user to the presence of uninsulated “dangerous voltage” within the product’s enclosure that may be of sufficient magnitude to constitute a risk of electric shock to persons.



The exclamation point within an equilateral triangle is intended to alert the user to the presence of important operating and maintenance (servicing) instructions in the literature accompanying the appliance.

**WARNING:** TO PREVENT FIRE OR SHOCK HAZARDS, DO NOT EXPOSE THIS APPARATUS TO RAIN OR MOISTURE.

**CAUTION:** TO INSURE PERSONAL SAFETY, OBSERVE THE FOLLOWING RULES REGARDING THE USE OF THIS UNIT.

1. Operate only from the power source specified on the unit.
2. Avoid damaging the AC plug and power cord.
3. Avoid improper installation and never position the unit where good ventilation is unattainable.
4. Do not allow objects or liquid into the cabinet openings.
5. In the event of trouble, unplug the unit and call a service technician. Do not attempt to repair it yourself or remove the rear cover.

Changes or modifications not approved by JVC could void the warranty.

- When you don't use this monitor for a long period of time, be sure to disconnect both the power plug from the AC outlet and antenna for your safety.
- To prevent electric shock do not use this polarized plug with an extension cord, receptacle or other outlet unless the blades can be fully inserted to prevent blade exposure.

---

**Do not attempt to service the product yourself**

---

**Caution**

To prevent electrical shock, do not open the cabinet.  
There are no user serviceable parts inside.  
Please refer to qualified service personnel for repairs.

---

## Important Safety Instructions

- 1) Read these instructions.
- 2) Keep these instructions.
- 3) Heed all warnings.
- 4) Follow all instructions.
- 5) Do not use this apparatus near water.
- 6) Clean only with dry cloth.
- 7) Do not block any ventilation openings. Install in accordance with the manufacturer's instructions.
- 8) Do not install near any heat sources such as radiators, heat registers, stoves, or other apparatus (including amplifiers) that produce heat.

- 9) Do not defeat the safety purpose of the polarized or grounding-type plug. A polarized plug has two blades with one wider than the other. A grounding type plug has two blades and a third grounding prong. The wide blade or the third prong are provided for your safety. If the provided plug does not fit into your outlet, consult an electrician for replacement of the obsolete outlet.
- 10) Protect the power cord from being walked on or pinched particularly at plugs, convenience receptacles, and the point where they exit from the apparatus.
- 11) Only use attachments/accessories specified by the manufacturer.
- 12) Use only with the cart, stand, tripod, bracket, or table specified by the manufacturer, or sold with the apparatus. When a cart is used, use caution when moving the cart/apparatus combination to avoid injury from tip-over.
- 13) Unplug this apparatus during lightning storms or when unused for long periods of time.
- 14) Refer all servicing to qualified service personnel. Servicing is required when the apparatus has been damaged in any way, such as power-supply cord or plug is damaged, liquid has been spilled or objects have fallen into the apparatus, the apparatus has been exposed to rain or moisture, does not operate normally, or has been dropped.
- 15) Apparatus shall not be exposed to dripping or splashing and no objects filled with liquids, such as vases, shall be placed on the apparatus.
- 16) Place the monitor on a stable, flat surface. Failure to do so can result in the monitor falling, causing injury.
- 17) DO NOT allow young children to play around or on the monitor. Do not hang from the monitor. Failure to do so can result in the monitor falling, causing injury.
- 18) To prevent electrical shock, do not open cover or take apart the AC adapter. Repair should be done by service personnel only.
- 19) Do not let the AC adapter hang down while using.
- 20) Do not cover or wrap the AC adapter with clothes or sheets or the like.
- 21) Leave space around the AC adapter to prevent overheating.



- 22) Use of power cords or AC adapters other than those provided may cause fire or malfunction.
- 23) DO NOT allow young children to play with the plastic bag that came with the monitor when you unpacked it. Failure to do so can result in suffocation, causing injury.
- 24) Avoid improper installation and never position the unit where good ventilation is impossible. When installing this monitor, distance recommendations must be maintained between the set and the wall, as well as inside a tightly enclosed area or piece of furniture. Keep to the minimum distance guidelines shown for safe operation.

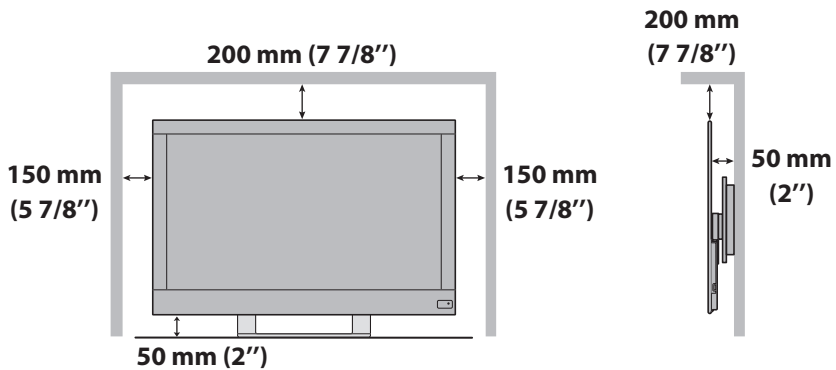

25) Cautions for installation

- Do not tilt the monitor towards the left or right, or towards the back.
- Install the monitor in a corner on the floor so as to keep cords out of the way.
- The monitor will generate a slight amount of heat during operation. Ensure that sufficient space is available around the monitor to allow satisfactory cooling.
- Have two people remove the monitor from the box with the screen facing away from you. It's possible your clothing, (such as a belt buckle or button) may scratch the front of the monitor. Do the same when moving the monitor to another location.

- 26) When installing the monitor on the wall, ask your dealer to install.
- 27) Make enough room for inserting and removing the power plug. Place the monitor as close to the outlet as possible. The main power supply for this monitor is controlled by inserting or removing the power plug.
- 28) Batteries shall not be exposed to excessive heat such as sunshine, fire or the like.
- 29) When this monitor is connected to the wall outlet, it is always on standby even when all the LED lamps are not lit. To shut down the monitor, unplug the monitor from the wall outlet.

### **To avoid burn-in**

Do not display a still picture for an extended period of time. Doing so may cause a faint image to remain on your screen.

## **Warning**

### **To prevent an accidental fall**

To prevent injury, the monitor must be fixed to the floor/cabinet. Use bolts and nuts or screws (ø 4 mm, sold separately) to fix the monitor to the floor/cabinet utilizing the holes of the stand.

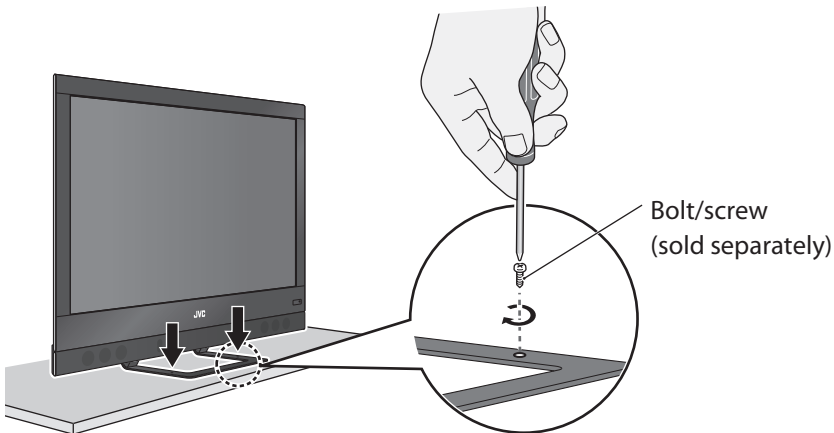

## Carrying the monitor

When carrying the monitor, hold it by the sides as illustrated.

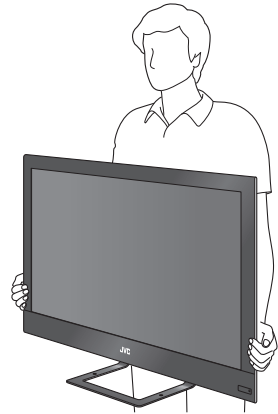

### IMPORTANT RECYCLING INFORMATION

This product has a fluorescent lamp that contains mercury. Disposal of these materials may be regulated in your community due to environmental considerations. For disposal or recycling information, please contact your local authorities or for USA, the Electronic Industries Alliance: <http://www.eiae.org>

#### **FCC Notice:**

**Caution:** Changes or modifications not expressly approved by party responsible for compliance could void the user's authority to operate the equipment.

**Note:** This equipment has been tested and found to comply with the limits for a Class B digital device, pursuant to Part 15 of the FCC Rules. These limits are designed to provide reasonable protection against harmful interference in a residential installation. This equipment generates, uses and can radiate radio frequency energy and, if not installed and used in accordance with the instructions, may cause harmful interference to radio communications. However, there is no guarantee that interference will not occur in a particular installation. If this equipment does cause harmful interference to radio or television reception, which can be determined by turning the equipment off and on, the user is encouraged to try to correct the interference by one or more of the following measures:

- Reorient or relocate the receiving antenna.
- Increase the separation between the equipment and receiver.
- Connect the equipment into an outlet on a circuit different from that to which the receiver is connected.
- Consult the dealer or an experienced radio/TV technician for help.



# Features

- › More precise adjustment of picture quality with a wide range of adjustment properties → page A-2
- › Enjoy SLR digital camera photographs → page A-11
- › Slim cabinet provides you with greater freedom of choice for installation
- › Quick response making video games more exciting — Game Mode → page A-5
- › Operating HDMI devices from the TV remote controller — HDMI CEC compatible → page 11



# Contents

Warning.....	ii
Installation .....	04
Included items	04
Inserting batteries into the remote control	04
Attaching the speaker unit	05
Installation	05
Connecting external devices	06
Connecting the power cable/AC adapter	08
Initial settings	08
Parts identification .....	09
Controlling HDMI devices.....	11
Changing the settings .....	12
Picture	13
Sound	25
Setup	27
HDMI	34
Viewing photographs on SD card/ USB device .....	36
External Control .....	40
Troubleshooting.....	44
Specifications .....	46
Index.....	56

## Technical information

<b>Adjust the picture to your needs .....</b>	<b>A-2</b>
<b>Set up the monitor for your PC .....</b>	<b>A-10</b>
<b>Enjoy SLR digital camera photographs .....</b>	<b>A-11</b>
<b>Menu index by task.....</b>	<b>A-12</b>

You can search for picture/sound menu items from the adjustment you want to make, and quickly find the page containing detailed information.

# Installation

## Included items

- Main unit (monitor)

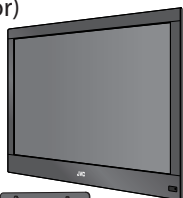

- Stand



- VESA bracket

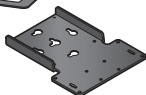

- M4 x 8 screws (for the stand or VESA bracket, x 4)

- M3 x 12 screw (for the HDMI cover, x 1)

- Remote control unit, AAA size batteries

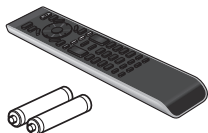

- Video cable (D-sub 15 pin / RCA)



- Audio cable (3.5 mm stereo mini / RCA)



- RS-232C extension cable



- Video cable (D-sub 15 pin)



- Power cable

- AC adapter

- HDMI cover, AC terminal cover, D-sub cover, hook hole covers (x 2), bottom covers (x 2)

- Instructions (this book), startup sheet, other printed material

## Inserting batteries into the remote control

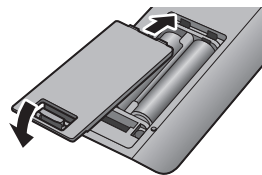
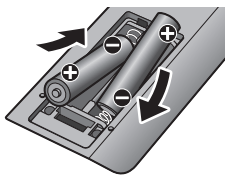

### When replacing the batteries

To avoid short-circuit, place the minus end of the batteries first.

- Batteries shall not be exposed to excessive heat such as direct sunshine, fire or the like.
- Read the precautions on the battery.
- The batteries last about 6 to 12 months on regular usage.
- The included batteries are supplied for operation check and may last shorter.



If this symbol is shown, it is only valid in the European Union

## Attaching the covers

- Attach the HDMI cover (3) and AC terminal cover (5) after connections have been made. Fix the HDMI cover to the unit using the supplied screw. Break off the bottom right of the HDMI cover when you want to extend the HDMI cable backwards.
- Attach the D-sub cover (1), hook hole covers (2) and bottom covers (4) when the respective openings are not in use.

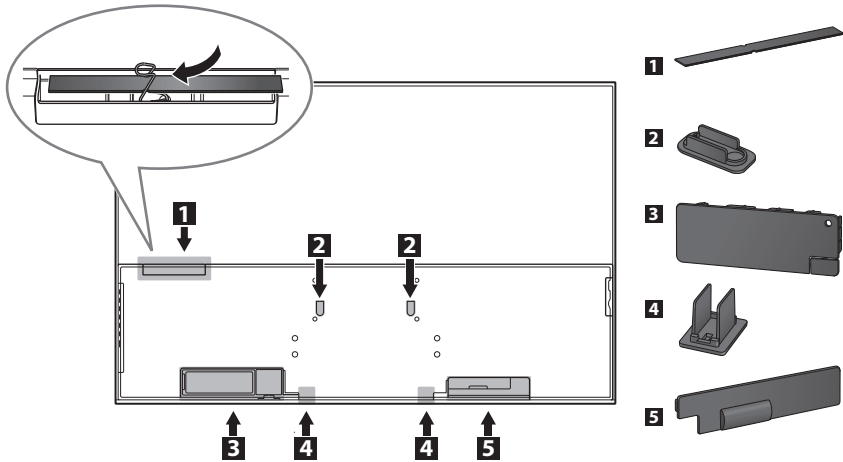

## Attaching the speaker unit

Connect the speaker unit (TS-C32SPG: sold separately) to the monitor if you do not connect any other external audio output device.

- Set the volume to the minimum level and turn the power off before you attach the speaker unit to the monitor.
- Refer to the startup sheet for details.

## Installation

Install the unit properly referring to the cautions from pages ii to vii.

- Attach the stand (supplied) to stand the monitor. Refer to the startup sheet for details.
- Attach the VESA bracket using the supplied screws when installing the monitor on the wall. Refer to the startup sheet for details. Consult a specialist when you install the monitor on the wall.

# Connecting external devices

## To connect a device with component terminals

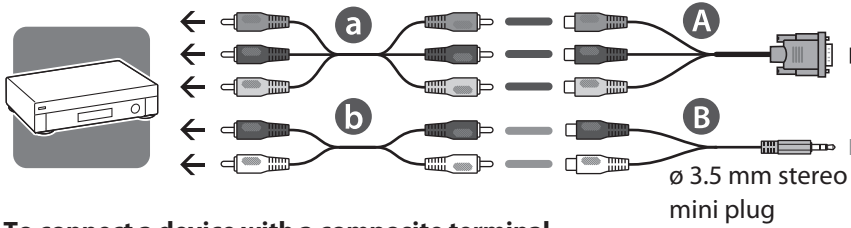

## To connect a device with a composite terminal

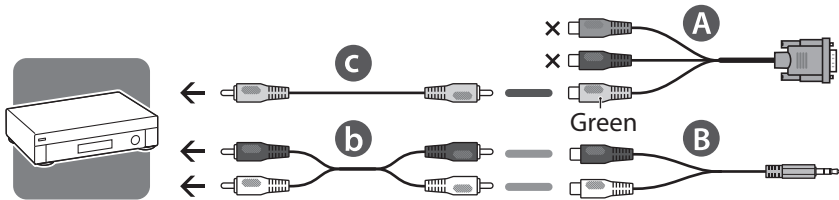

## To connect a computer



## To connect a DVI device

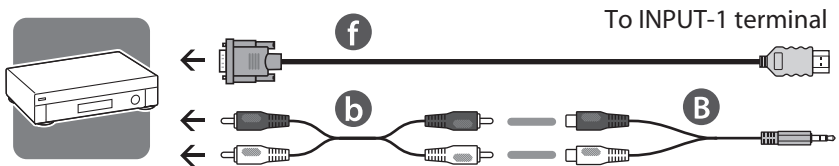

## To connect an HDMI device



- HDMI™ (V.1.3, with Deep Color, with x.v.Color™, HDMI™ CEC Support)

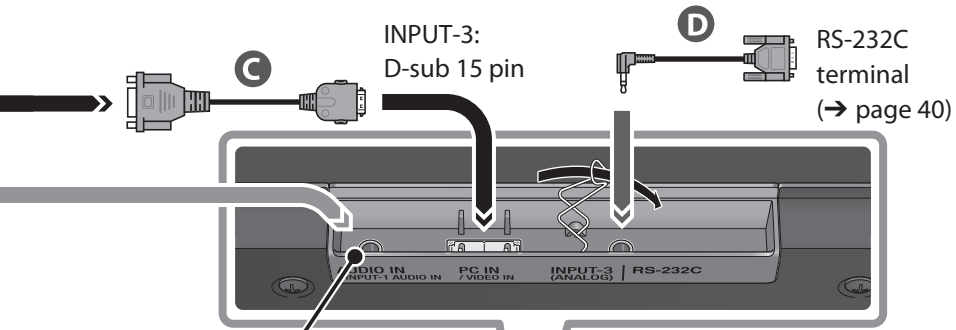

AUDIO IN terminal :  
3.5 mm stereo mini  
jack

INPUT-2: HDMI™ terminal

INPUT-1: HDMI™  
terminal

INPUT-4 :  
SD card slot,  
USB type slot  
(→ page 36)

- |                                       |                                     |
|---------------------------------------|-------------------------------------|
| A: Video cable (supplied)             | d: VGA cable (sold separately)      |
| B: Audio cable (supplied)             | e: Audio cable (sold separately)    |
| C: Video cable (supplied)             | f: DVI-HDMI cable (sold separately) |
| D: RS-232C extension cable (supplied) | g: HDMI cable (sold separately)     |
| a: Component cable (sold separately)  |                                     |
| b: Audio cable (sold separately)      |                                     |
| c: Video cable (sold separately)      |                                     |

- When using the INPUT-3 terminal, set "Input-3 Setting" (→ page 31) properly according to the connected device.
- To reduce noise, use a VGA cable with core filters.
- When you connect a DVI device to INPUT-2, only the video signal is played back, and the sound signal is not.

## Connecting the power cable/AC Adapter

- Connect AC plug adapter and power cord to the monitor in the order of numbers below.
- Insert the power terminal firmly until you hear a clicking sound.

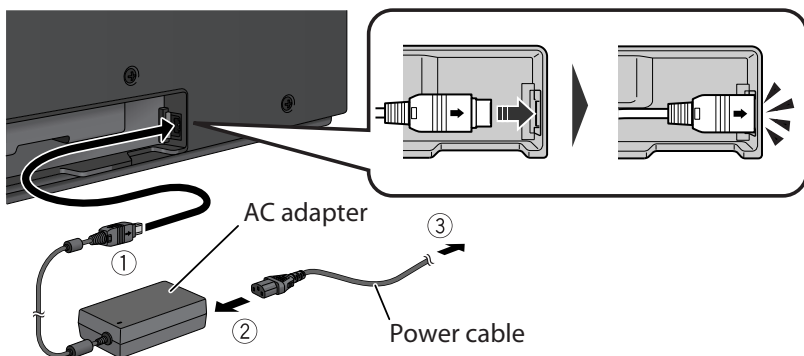

- Ground the earth plug of the power cable to the earth terminal of the AC outlet.

## Initial settings

When you turn on the monitor for the first time, initial settings start. Select the menu language and the place of installation.

### 1 Select the menu language.

1-1 Select "Menu Language" and press the [OK] button.

1-2 Select from the list the language you want using the [▲▼] buttons, and press the [OK] button.

1-3 Select [Set] and press the [OK] button.

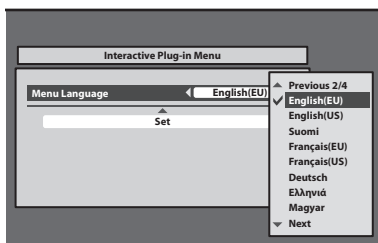

### 2 Select the place of installation.

2-1 Select "Place of Installation" and press the [OK] button.

2-2 Select the place of installation using the [▲▼] buttons, and press the [OK] button.

2-3 Select [Set] and press the [OK] button.

- Whichever place you select in step 2, settings and functions are the same.
- In steps 1-1 and 2-1, you can also select a setting by pressing the [◀▶] buttons.

# Parts identification

## Main unit

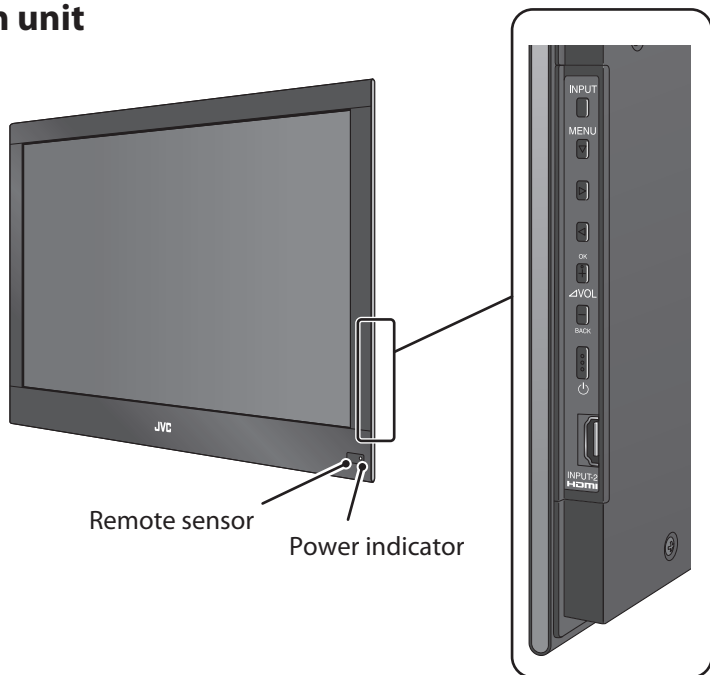

---

Power indicator Lights while the monitor is on.

---

Remote sensor Aim the remote control here.

---

---

 Turns the monitor on/off (on standby).

---

**INPUT** Switches the input.

---

**MENU ▾** Opens the setting menu. Functions as the down cursor key in the menu operations.

---

**◀ ▶** Functions as the left cursor key and the right cursor key in the menu operations.

---

**+ OK** Turns up the volume. Functions as the OK key in the menu operations.

---

**- BACK** Turns down the volume. Functions as the BACK key in the menu operations.

---



## Remote control

<b>POWER</b>	Turns the monitor on/off (on standby).
<b>LINK</b>	Opens the photo viewer menu or the operation window for HDMI CEC devices. (→ page 11)
<b>OPTION</b>	Opens the setup window of HDMI CEC devices. Opens the setting menu of the photo viewer (→ page 38).
<b>MENU</b>	Opens the setting menu. (→ page 12)
<b>EXIT</b>	Exits from the menu.
<b>▲▼◀▶</b> (Cursor keys)	Selects an item.
<b>OK</b>	Confirms your selection.
<b>BACK</b>	Goes back to the previous screen.
<b>ASPECT</b>	Changes the aspect. (→ page 28)
<b>BLUE</b>	Press accordingly to the on-screen indications.
<b>RED</b>	
<b>GREEN</b>	
<b>YELLOW</b>	
<b>VOL +/-</b>	Adjusts the volume.
<b>MUTING</b>	Attenuates the sound.
<b>INPUT 1</b>	Switches the input.
<b>INPUT 2</b>	
<b>INPUT 3</b>	
<b>INPUT 4</b>	

- Buttons not mentioned above are equipped for the operations of a TV tuner.

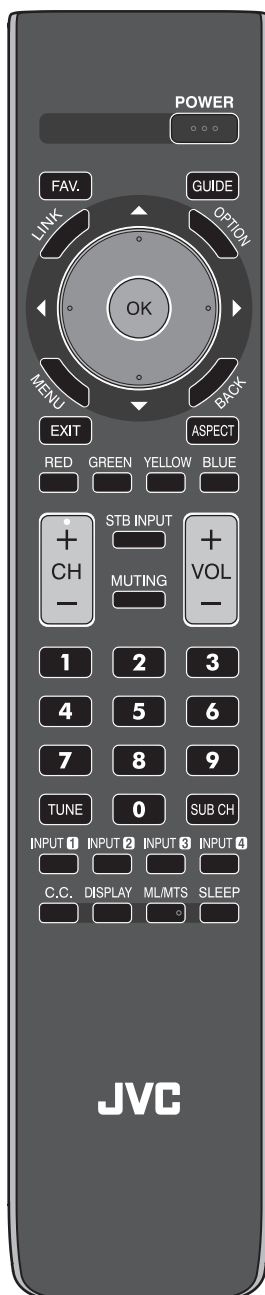

# Controlling HDMI devices

You can control HDMI CEC devices connected to this monitor using the remote of the monitor.

- This function can be customized in the “HDMI” settings (→ page 34).
- Devices may not operate or may function differently from described, depending on the model or the manufacturer.

## 1 Press the [LINK] button.

Operation window appears.

## 2 Select the device to control.

Select the device name under “Device”.

## 3 Control the selected HDMI device.

- “Rec.” : Starts recording.
- “Rec.Stop” : Stops recording.
- “NAVIGATION” : Opens the playback menu of the HDMI device.
- “Function” : Opens the operation menu of the HDMI device.
- “Operation Panel” : Opens the operation panel.

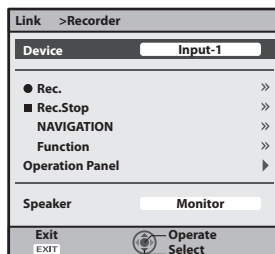

### To select the audio output

When an HDMI CEC amplifier is connected to the monitor, you can select either the monitor or the amplifier as the device to output the sound signal.

- To output the sound from the amplifier, set “AMP Control” (→ page 35) to “On”, and connect the audio output terminals of the player into the amplifier.

#### 1 Press the [LINK] button.

#### 2 Select “Monitor” or “AMP” under “Speaker”.

- “Monitor” : The sound is output from the speakers when you connect the speaker unit (sold separately) to the monitor. The volume buttons of the monitor control the volume of the speakers.
- “AMP” : The sound is output from the amplifier. The volume buttons of the monitor control the volume of the amplifier.

# Changing the settings

Example: to change the setting of "Color Temperature"

## 1 Open the menu.



## 2 Select "Picture".

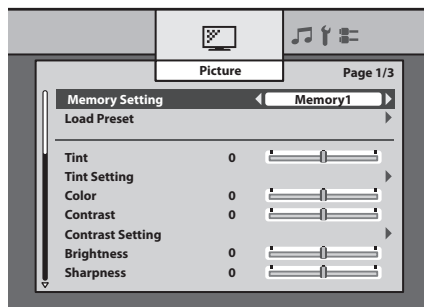
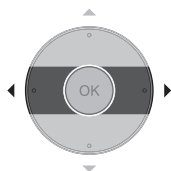

## 3 Select "Color Temperature".

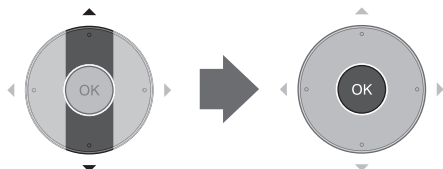

● The item currently selected is shown in orange.

## 4 Select the setting you want.

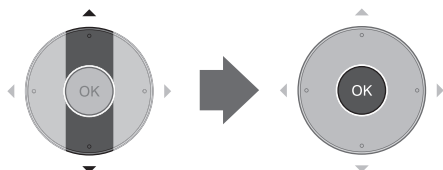

● When the selected item is followed by an adjustment screen, press the [◀▶] buttons to make adjustments.

## 5 Finish the setting.



Picture  → page 13

Sound  → page 25

Setup  → page 27

HDMI  → page 34

# Technical information

<b>Adjust the picture to your needs</b>	<b>A-2</b>
<b>Set up the monitor for your PC</b>	<b>A-10</b>
<b>Enjoy SLR digital camera photographs</b>	<b>A-11</b>
<b>Menu index by task</b>	<b>A-12</b>



*Show Your True Colors.*

# Adjust the picture to your needs

Make picture adjustments according to your needs using the “Picture” menu.

- You can save six sets (“memories”) of your adjustments.
- You can load a preset into memory and use it as it is, or make your own adjustment.

## To use a preset

- 1 Open the menu.
- 2 Select a memory from “Memory Setting” in “Picture”.

- When you select one of the memory, its settings are applied to the picture.

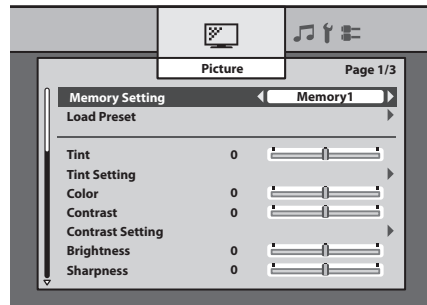

- 3 Select “Load Preset”, select one of the preset settings, and press “Load”.

- See page A-4 for the detail of presets.
- In the initial setting, all the six memories are set to the preset of “Monitor”.

This monitor features rich menus for picture control, in addition to 10 pre-installed sets of picture settings carefully prepared by JVC to suit various types of video content and viewing environment.

Enjoy controlling appearance of pictures using the "Picture" menu, and create your own picture settings.

## To customize the settings

You can create your own set of picture settings by arranging the settings of a preset. Storing several sets of settings helps you to enjoy a picture in the taste you like according to the viewing environment and characteristics of the source.

### 1 Open the menu.

### 2 Select the memory you want to adjust from "Memory Setting" in "Picture".

### 3 Adjust items in "Picture".

→ See pages 14 and later for the detail of menu items.

- It is recommended to use the preset of "Standard" as the base of your adjustment.
- Adjustments are stored into the selected memory as you change the settings.
- To make another set of picture settings, select another memory in step 2 above and start adjustments.

## To reset the settings

If you do not like your current adjustments, load either of the preset settings into the memory which you want to reset. Settings of the selected memory are overwritten by those of the loaded preset setting.

### 1 Open the menu.

### 2 Select the memory you want to reset from "Memory Setting" in "Picture".

### 3 Select "Load Preset", select one of the preset settings, and press "Load".

## ● Characteristics of the 10 presets

### Dynamic

---

Makes pictures colorful and bright, suitable for watching in a well-light room.



### Standard

---

The most standard setting.



### Theater

---

Suitable for watching cinemas in a dark room.



### Monitor

---

Does not apply color adjustments or noise reductions. Input video signals are displayed as they are. Suitable for monitoring purpose.

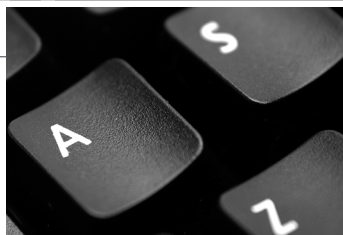

### Photo Pro

---

Suitable for watching still pictures of SLR digital cameras.





## Game

Gives priority to the response time for picture movement.  
Suitable for game consoles.

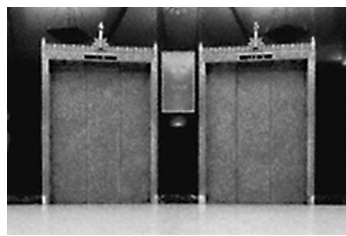

## Signage

Suitable for digital signage use in market, shops or hotels.



## CCTV HD

Suitable for monitoring CCTVs in HD format.



## CCTV SD

Suitable for monitoring CCTVs in SD format.

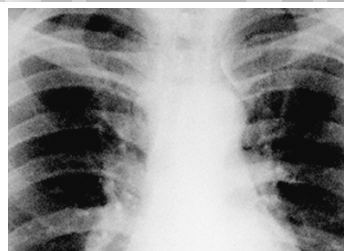

## Option

Suitable for displaying medical images including x-ray pictures.

- This setting is only for approximate presentation and does not conform to any official standard of medical imaging.

→ See the following pages for the setting values of each preset.



## ● Setting values of each preset

- The settings are subject to change for amelioration.

	<b>Dynamic</b>	<b>Standard</b>	<b>Theater</b>	<b>Monitor</b>
Tint	0	0	0	0
Tint Setting				
BY Gain	0	0	0	0
BY/RV Angle	0	+2	+3	0
Color	+8	+4	+2	0
Contrast	+3	0	0	0
Contrast Setting				
Black Stretch	High	Medium	Off	Off
Dynamic DC Offset	On	On	On	Off
Auto Contrast	On	Off	Off	Off
Brightness	0	0	+2	0
Sharpness	+10	0	0	-30
Enhancer	Mode-2	Mode-2	Mode-3	Mode-3
Enhancer Setting				
Detail	0	-5	0	0
H.Sharp	+10	+5	+10	0
V.Sharp	+10	+5	+5	0
Backlight	+30	+5	-5	0
Backlight Setting				
Smart Picture	Off	On	On	Off
Dynamic Backlight	High	Medium	Low	Off
Color System	Auto	Auto	Auto	Auto
Color Matrix	Auto	Auto	Auto	Auto
Color Space	Auto	Auto	Normal	Normal
Color Temperature	Mode-2	Mode-3	Mode-5	Mode-5

	<b>Photo Pro</b>	<b>Game</b>	<b>Signage</b>	<b>CCTV HD</b>	<b>CCTV SD</b>	<b>Option</b>
	0	0	0	0	0	0
	0	0	0	0	0	0
	0	0	0	0	0	0
	0	0	+5	+8	+14	0
	0	0	0	+4	+5	0
	Off	Off	Medium	High	High	Off
	Off	Off	Off	Off	Off	Off
	Off	Off	On	On	On	Off
	0	0	0	0	-4	+2
	0	-15	-10	20	20	-30
	Mode-3	Mode-3	Mode-3	Mode-1	Mode-1	Mode-3
	-15	0	0	0	0	0
	-5	0	0	0	+5	0
	-15	0	-15	0	-5	0
	+5	+10	+30	+30	+30	+18
	Off	On	Off	Off	Off	Off
	Off	Off	Medium	Medium	Medium	Off
	Auto	Auto	Auto	Auto	Auto	Auto
	Auto	Auto	Auto	Auto	Auto	Auto
	sRGB	Auto	Wide	Wide	Wide	Normal
	Mode-5	Mode-2	Mode-2	Mode-3	Mode-3	Mode-4

	<b>Dynamic</b>	<b>Standard</b>	<b>Theater</b>	<b>Monitor</b>	
<b>White Balance Setting</b>					
R Drive / G Drive / B Drive	0	0	0	0	
R Cutoff / G Cutoff / B Cutoff	0	0	0	0	
Color Management	Mode-1	Mode-2	Mode-3	Off	
<b>Color Mngmt. Setting</b>					
Red Tint / Red Color	0	0	0	0	
Yellow Tint / Yellow Color	0	0	0	0	
Green Tint / Green Color	0	0	0	0	
Cyan Tint / Cyan Color	0	0	0	0	
Skin Tint / Skin Color	0	0	0	0	
Color : Bright Area	0	0	0	0	
Color : Dark Area	0	0	0	0	
Gamma	Mode-2	Mode-2	Mode-3	Mode-3	
Dynamic Gamma	High	Medium	Low	Off	
<b>Noise Reduction</b>					
Digital VNR	Auto	Auto	Auto	Off	
MPEG NR	Low	Low	Low	Off	
3DY/C	On	On	On	Off	
Natural Cinema	Auto	Auto	Auto	Off	
Picture Delay Time	Normal	Normal	Normal	Normal	
PC Monitor Mode	Off	Off	Off	Off	
Eco Mode	Off	Off	Off	Off	
<b>Other</b>					
Real Bit Driver	On	On	On	Off	
100/120Hz CMD	On	On	On	Off	

	Photo Pro	Game	Signage	CCTV HD	CCTV SD	Option
	0	0	0	0	0	0
	0	0	0	0	0	0
	Off	Mode-2	Mode-1	Mode-2	Mode-1	Off
	0	0	0	0	0	0
	0	0	0	0	0	0
	0	0	0	0	0	0
	0	0	0	0	0	0
	0	0	0	0	0	0
	0	0	0	0	0	0
	0	0	0	0	0	0
	Mode-3	Mode-2	Mode-3	Mode-4	Mode-2	Mode-6
	Off	Medium	Medium	Medium	High	Off
	Auto	Auto	Auto	Auto	Auto	Off
	Off	Low	Low	Low	Low	Off
	On	On	On	On	On	Off
	Off	Off	Off	Off	Off	Off
	Normal	Middle	Normal	Normal	Normal	Short
	Off	Off	Off	Off	Off	Off
	Off	Off	Off	Off	Off	Off
	On	On	On	On	On	Off
	Off	On	Off	On	On	Off

# Set up the monitor for your PC

## Selecting the input signal

When you connect a PC to the INPUT-3 terminal, set the type of the input signal accordingly.

### ● For signals in VGA60 and XGA60

Set "Sampling Mode" to "Std". (→ page 32)

### ● For signals in WVGA60

Set "Sampling Mode" to "Wide". (→ page 32)

### ● For signals in WXGA (1280), WXGA (1360) and WXGA60

1 Set "Sampling Mode" to "Wide". (→ page 32)

2 Set "WXGA Select" as follows. (→ page 32)

- For signals in WXGA (1280): "1280\*768"
- For signals in WXGA (1360): "1360\*768"
- For signals in WXGA60: "1366\*768"

### ● For signals in SXGA60

Set "SXGA / SXGA+" to "SXGA". (→ page 32)

### ● For signals in SXGA+60

Set "SXGA / SXGA+" to "SXGA+". (→ page 32)

**If the picture is not aligned vertically, or letters on the screen look blurred**

Set the aspect to "1:1", and adjust "Dot Clock" and "Clock Phase". (→ page 33)

- For signals in 1920 x 1080, set the aspect to "Full" and adjust the same items.

**If the picture is cropped, or extra margins are displayed around it**

- 1 Set the aspect to "Full".**
- 2 Adjust the position of the picture using "PC Position Adjustment" until the upper left corner of the picture is positioned at the upper left corner of the display.**
- 3 Adjust the size of the picture using "H Size" and "V Size" until the bottom right corner of the picture is positioned at the bottom right corner of the display.**

## Enjoy SLR digital camera photographs

When you select the picture preset of "Photo Pro" in "Memory Setting", you can view the photographs just the way they were taken.

You can also view photographs on an SD card or USB device using Photo viewer. (→ page 36)

For JPEG pictures, select "sRGB" or "AdobeRGB" under the setting of "Color Space" (→ page 18) according to the setting of your camera, so that the photographs are displayed more faithfully to the original.

- It is recommended not to modify the settings of "Photo Pro". In the initial setting of "Photo Pro", "Color Space" is set to "sRGB".

## Menu index by task

		Page	
Hue adjustment	General tone of color	Tint	14
	Tone of color (including white)	Color Temperature	19
	Tone of color (in detail)	White Balance Setting	19
	Range of color representation	Color Space	18
	Amplitude of the color difference signal	Tint Setting > BY Gain	14
	Demodulation angle of the color difference signal	Tint Setting > BY/RV Angle	14
	Pattern of color correction	Color Management	20
	Color correction (in detail)	Color Mngmt. Setting > Red Tint, Yellow Tint, etc.	20
Color adjustment	Total density of color	Color	14
	Amplitude of the color difference signal	Tint Setting > BY Gain	14
	Demodulation angle of the color difference signal	Tint Setting > BY/RV Angle	14
	Pattern of color correction	Color Management	20
	Color correction (in detail)	Color Mngmt. Setting > Red Color, Yellow Color, etc.	20
Brightness (backlight)	Total brightness of pictures	Backlight	16
	Reduces backlight in bright scenes	Backlight Setting > Smart Picture	17
	Reduces backlight in dark scenes	Backlight Setting > Dynamic Backlight	17
	Adjusts backlight depending on the luminance of the room	Eco Mode	24
Brightness (signal)	Total brightness of pictures	Brightness	15
	Adjusts the gain of the signal level	Contrast	15
	Emphasizes darker areas automatically	Contrast Setting > Black Stretch	15
	Reduces brightness in bright scenes	Contrast Setting > Dynamic DC Offset	15
	Emphasizes bright areas automatically	Contrast Setting > Auto Contrast	15
	Gamma correction value	Gamma	21
	Adjusts gamma value automatically	Dynamic Gamma	21
Sharpness	Sharpness	Sharpness	16
	Sharpness (in detail)	Enhancer Setting	16
	Frequency band to enhance	Enhancer	16
Sound	Bass sound	Bass	25
	Treble sound	Treble	25
	Equalizer suited for the speakers	PEQ	26
	Adjusts the delay time of sound	Lip Sync	25

## Picture

### Memory Setting

You can store up to 6 sets of the “Picture” settings and use them.

- When the input is changed, the memory used for the input last time is automatically applied.

■ **Memory1 / Memory2 / Memory3 / Memory4 / Memory5 / Memory6**

### Load Preset

You can load one of the presets below into a memory.

You can do further adjustment based on the loaded settings.

- Select a preset and press “Load” to load a preset.
- **Dynamic** : Makes pictures colorful and bright, suitable for watching in a well-light room.
- **Standard** : The most standard setting.
- **Theater** : Suitable for watching cinemas in a dark room.
- **Monitor** : Does not apply color adjustments or noise reductions. Input video signals are displayed as they are.
- **Photo Pro** : Suitable for watching still pictures of SLR digital cameras.
- **Game** : Gives priority to the response time for picture movement. Suitable for game consoles.
- **Signage** : Suitable for digital signage use in market, shops or hotels.
- **CCTV HD** : Suitable for monitoring CCTVs in HD format.
- **CCTV SD** : Suitable for monitoring CCTVs in SD format.
- **Option** : Suitable for displaying medical images including x-ray pictures.
  - This setting is only for approximate presentation and does not conform to any official standard of medical imaging.





## Tint

Adjusts the tone of color.

- **-30 – +30** (Skin color reddish ↔ Skin color greenish)

## Tint Setting

Adjusts the tone of color in detail.

- The setting is fixed to 0 and unadjustable when “Color Space” is set to “sRGB”, “AdobeRGB”, or “x.v.Color”.
- The setting is fixed to 0 and unadjustable when “Color Space” is set to “Auto” and the xvYCC signal is input to the HDMI terminal.
- The setting is fixed to 0 and unadjustable when “PC Monitor Mode” is set to “On”.

### ◆ **BY Gain**

Adjusts the amplitude of the B-Y color difference signal. You can modify the total coloring of the picture.

- **-30 – +30** (Small amplitude ↔ Large amplitude)

### ◆ **BY/RY Angle**

Adjusts the demodulation angle between the B-Y color difference signal and the R-Y color difference signal. You can modify the total coloring of the picture.

- **-15 – +15** (Decreasing the angle ↔ Increasing the angle)

## Color

Adjusts the density of color.

- **-30 – +30** (Dilute ↔ Dense)

## Contrast

Adjusts the brightness of brighter areas of pictures.

- **-30 – +30** (Dark ↔ Bright)

## Contrast Setting

Adjusts settings of functions relating with contrast.

- The functions are not available when “Color Space” is set to “sRGB” or “AdobeRGB”.
- The functions are not available when “PC Monitor Mode” is set to “On”.

### ◆ **Black Stretch**

Emphasizes darker areas depending on the characteristics of a picture to make contrast clearer.

- **High / Medium / Low / Off**

### ◆ **Dynamic DC Offset**

Controls the blackness of the picture automatically depending on the total brightness.

- **On / Off**

### ◆ **Auto Contrast**

Emphasizes brighter areas depending on the characteristics of a picture to make contrast clearer.

- **On / Off**

## Brightness

Adjusts blackness.

- **-30 – +30** (Dark ↔ Bright)



## Sharpness

Emphasizes outlines on a picture.

- The setting is unadjustable when “Enhancer” is set to “Off”.
- **-30 – +30** (Fuzzy ↔ Sharp)

## Enhancer

Selects the frequency band enhanced by “Sharpness”.

- **Off** : Deactivates the function.
- **Mode-1 / Mode-2 / Mode-3**  
(Emphasizes lower frequency band; for low-resolution picture ↔  
Emphasizes higher frequency band; for high-resolution picture)

## Enhancer Setting

Adjusts the effects of “Enhancer” in detail.

- All the settings are unadjustable when “Enhancer” is set to “Off”.

### ◆ Detail

Adjusts texture of surface.

- **-15 – +15** (Weaker ↔ Stronger)

### ◆ H.Sharp

Adjusts sharpness of horizontal outlines.

- **-15 – +15** (Weaker ↔ Stronger)

### ◆ V.Sharp

Adjusts sharpness of vertical outlines.

- **-15 – +15** (Weaker ↔ Stronger)

## Backlight

Adjusts the brightness of backlight.

- **-30 – +30** (Darker ↔ Brighter)

## Backlight Setting

Adjusts settings of functions relating with backlight.

### ◆ Smart Picture

Reduces the backlight automatically in dazzling scenes.

■ **On / Off**

### ◆ Dynamic Backlight

Reduces the backlight automatically in dark scenes to represent black deeper.

■ **High / Medium / Low / Off**

## Color System

Selects the color system for the picture signal which is input to INPUT-3 from composite terminal.

- The setting is adjustable only when "Input-3 Setting" is set to "Composite".  
(→ page 31)
- The setting is unadjustable when "PC Monitor Mode" is set to "On".
- **Auto** : An appropriate color system is automatically applied depending on the type of the input signal. Normally select this.
- **PAL/50** : When the color system is PAL.
- **PAL/60** : When the color system is PAL 60.
- **SECAM** : When the color system is SECAM.
- **NTSC3.58** : When the color system is NTSC 3.58.
- **NTSC4.43** : When the color system is NTSC 4.43.
- **PAL M** : When the color system is PAL-M.
- **PAL N** : When the color system is PAL-N.



## Color Matrix

Selects the color matrix used for color conversion.

- The setting is fixed to "Auto" and unadjustable when "Color Space" is set to "sRGB", "AdobeRGB", or "x.v.Color".
- The setting is fixed to "Auto" and unadjustable when "PC Monitor Mode" is set to "On".
- The setting is fixed to "Auto" and unadjustable when "Color Space" is set to "Auto" and the xvYCC signal is input to the HDMI terminal.
- **Auto** : An appropriate color matrix is applied automatically.
- **709** : The color matrix conforming ITU-R BT.709 is used for conversion.
- **601** : The color matrix conforming ITU-R BT.601 is used for conversion.

## Color Space

Changes the range of color representation.

- "sRGB" or "AdobeRGB" is selectable when "PC Monitor Mode" is set to "On".
- Even when "Auto" is selected, the setting may not switch to "x.v.Color" automatically depending on the connected device or the connection status.
- **Auto** : Normally applies "Wide". When the xvYCC signal is input to the HDMI terminal, "x.v.Color" is applied automatically. When the Photo viewer is selected, "Normal" is applied automatically.
- **Normal** : HDTV standard.
- **Wide** : The wide color gamut of the equipped LCD panel. (Wider than the HDTV standard.)
- **x.v.Color** : Color representation suitable for x.v.Color.
- **sRGB** : Color representation suitable for sRGB.
- **AdobeRGB** : Color representation suitable for AdobeRGB.

## Color Temperature

Adjusts the color temperature (color tone). The higher the color temperature, the more bluish the picture.

- The setting is fixed to "Mode-5" and unadjustable when "Color Space" is set to "sRGB" or "AdobeRGB".
- The setting is fixed to "Mode-5" and unadjustable when "PC Monitor Mode" is set to "On".
- **Mode-1** : Bluish display. (approx. 13000 K)
- **Mode-2** : Less bluish than "Mode-1". (approx. 11000 K)
- **Mode-3** : For general purpose. (approx. 9300 K)
- **Mode-4** : For special purposes including medical imaging. (approx. 8000 K)
- **Mode-5** : Standard setting. (approx. 6500 K)
- **Mode-6** : For conformation of images for printing. (approx. 5000 K)
- **Mode-7** : Significantly reddish setting intended for special usages in television studios. (approx. 3200 K)

## White Balance Setting

Adjusts color temperature in detail; subtle control of RGB gradations.

- These settings are independent of the setting of "Color Temperature".
- ◆ **R Drive / G Drive / B Drive**  
Adjusts the depth of R/G/B on bright areas.
  - **-30 - +30** (Dilute ↔ Dense)
- ◆ **R Cutoff / G Cutoff / B Cutoff**  
Adjusts the depth of R/G/B on dark areas.
  - **-30 - +30** (Dilute ↔ Dense)



## Color Management

Adjusts the total coloring of pictures. Three color management presets are available to suit a variety of color temperature settings.

- The setting is fixed to "Off" and unadjustable when "Color Space" is set to "sRGB", "AdobeRGB", or "x.v.Color".
- The setting is fixed to "Off" and unadjustable when "PC Monitor Mode" is set to "On".
- The setting is fixed to "Off" and unadjustable when "Color Space" is set to "Auto" and the xvYCC signal is input to the HDMI terminal.
- **Mode-1** : Improving the vividness of colors. Suitable for high color temperature.
- **Mode-2** : Standard colors. Suitable for medium color temperature.
- **Mode-3** : Improving the total toning of colors. Suitable for low color temperature.
- **Off** : Deactivates the function.

## Color Mngmt. Setting

Adjusts the total coloring of pictures in detail.

- All the settings are fixed to 0 and unadjustable when "Color Management" is set to "Off".
  - All the settings are fixed to 0 and unadjustable when "Color Space" is set to "sRGB", "AdobeRGB", or "x.v.Color".
  - All the settings are fixed to 0 and unadjustable when "PC Monitor Mode" is set to "On".
  - All the settings are fixed to 0 and unadjustable when "Color Space" is set to "Auto" and the xvYCC signal is input to the HDMI terminal.
- ◆ **Red Tint / Red Color**  
Adjusts the tone/colorfulness of red colors.  
■ **-15 – +15** (Magenta ↔ Yellow) / **-30 – +30** (Dilute ↔ Dense)
- ◆ **Yellow Tint / Yellow Color**  
Adjusts the tone/colorfulness of yellow colors.  
■ **-15 – +15** (Red ↔ Green) / **-30 – +30** (Dilute ↔ Dense)



### ◆ **Green Tint / Green Color**

Adjusts the tone/colorfulness of green colors.

- **-15 – +15** (Yellow ↔ Cyan) / **-30 – +30** (Dilute ↔ Dense)

### ◆ **Cyan Tint / Cyan Color**

Adjusts the tone/colorfulness of blue colors.

- **-15 – +15** (Green ↔ Blue) / **-30 – +30** (Dilute ↔ Dense)

### ◆ **Skin Tint / Skin Color**

Adjusts the tone/colorfulness of skin colors.

- **-15 – +15** (Red ↔ Yellow) / **-30 – +30** (Dilute ↔ Dense)

### ◆ **Color : Bright Area**

Adjusts the color depth of bright areas.

- **-15 – +15** (Dilute ↔ Dense)

### ◆ **Color : Dark Area**

Adjusts the color depth of dark areas.

- **-15 – +15** (Dilute ↔ Dense)

## Gamma

Adjusts the gamma correction value and controls the brightness and gradation of intermediately bright areas.

- **Mode-1** : For confirmation of images for printing. (Equivalent to  $\gamma$  1.8)
- **Mode-2** : For general purpose. (Equivalent to  $\gamma$  2.0)
- **Mode-3** : Standard setting. (Equivalent to  $\gamma$  2.2)
- **Mode-4** : Setting designed according to general CRT property. (Equivalent to  $\gamma$  2.4)
- **Mode-5** : For viewing digital cinemas. (Equivalent to  $\gamma$  2.6)
- **Mode-6** : For special purposes including medical imaging. Complies with GSDF (Grayscale Standard Display Function).
- **Mode-7** : Dark areas are brighter when compared to “Mode-3”.

## Dynamic Gamma

Adjusts gamma value automatically depending on the brightness of pictures.

- **High / Medium / Low / Off**



# Noise Reduction

Adjusts the settings of picture noise reduction.

- The functions are unavailable when "PC Monitor Mode" is set to "On" or when signals in a PC signal format are coming in.

## ◆ Digital VNR

Reduces picture noise.

- **Auto** : Estimates the amount of noise automatically and applies suitable noise reduction processing.
- **High / Medium / Low / Off**

## ◆ MPEG NR

Reduces noise on MPEG pictures such as mosquito-noise and block-noise.

- **High / Low / Off**

# 3DY/C

Detects the type of the picture signal (movie or still picture) which is input to INPUT-3 from composite terminal and applies a suitable Y/C separation process to each type.

- Unavailable when "Picture Delay Time" is set to "Short".
- Unavailable when the format of the incoming signal is other than NTSC 3.58, PAL50, PAL M or PAL N.
- **On / Off**



## Natural Cinema

Displays quick-moving parts on cinemas originally taken on films with more clarity.

- The setting is fixed to "Off" and unadjustable when "Picture Delay Time" is set to "Short".
- The setting is fixed to "Off" and unadjustable when "PC Monitor Mode" is set to "On".
- The setting is fixed to "Off" and unadjustable when progressive picture signal is input.

■ **Auto / Off**

## Picture Delay Time

Adjusts the time spent for picture-improving processes. The delay time becomes shorter though picture quality is down when the processes are skipped.

- The setting is fixed to "Short" and unadjustable when "PC Monitor Mode" is set to "On".

■ **Normal** : The picture-improving processes are fully applied, giving priority to picture quality.

■ **Middle** : Some picture-improving processes are skipped to decrease the delay time.

■ **Short** : Most of picture-improving processes are skipped to decrease the delay time more.

## PC Monitor Mode

Sets the monitor for use as a PC monitor.

- Only menu items which are necessary for PC monitors are activated.
- Input signals from HDMI terminals are recognized as PC signals (R:G:B = 4:4:4) and are processed appropriately.

■ **On / Off**

## Eco Mode

Adjusts the brightness of backlight depending on the luminance of the room to reduce power consumption.

- **Display** : Activating the function and indicating its performance.
- **On** : Activating the function. Its performance is not indicated.
- **Off** : Deactivates the function.

## Other

### ◆ Real Bit Driver

Makes the gradation of 8 bit signals natural and smooth.

- Also effective on signals not in 8 bit.

■ **On / Off**

### ◆ 100/120Hz CMD

Doubles the number of frames per second to reduce image blur.

- The setting is fixed to "Off" and unadjustable when "Color Space" is set to "sRGB" or "AdobeRGB".
- The setting is fixed to "Off" and unadjustable when "Picture Delay Time" is set to "Short".
- The setting is fixed to "Off" and unadjustable when "PC Monitor Mode" is set to "On".

■ **On / Off**

## Sound

- The following settings are only adjustable when the dedicated speaker unit (sold separately) is connected.
- The following settings are not adjustable while using the Photo viewer (→ page 36).

## Bass

Adjusts bass tone.

- **-6 – +6** (Weaker ↔ Stronger)

## Treble

Adjusts treble tone.

- **-6 – +6** (Weaker ↔ Stronger)

## Balance

Adjusts sound balance.

- **L10 – 10R** (To the left ↔ To the right)

## Auto Volume Control

Turns down the volume automatically when an excessive strong sound signal is input.

- **On / Off**

## Lip Sync

Adjusts the delay time of sound.

- **-3 – +3** (The sound starts earlier ↔ The sound starts later)



## PEQ

Optimizes the sound quality for the dedicated speaker unit (TS-C32SPG: sold separately). When the speaker unit is connected, setting "PEQ" to "On" brings high and low tones into balance, making the sound clearer. Select "Off" when connecting other speakers.

- "PEQ" stands for "Parametric Equalizer".

- **On / Off**

## Turn On Volume

Adjusts the initial volume when turning on the monitor.

- **0 – 50**

- **Current** : Setting the current volume to the initial.

- If the setting value surpass that of "Volume Limit", the initial volume at turning on becomes the maximum value set for "Volume Limit".
- Amplifiers connected to an HDMI terminal ignore this setting.

## Volume Limit

Sets the maximum volume to prevent unexpectedly loud sound reproduction.

- **0 – 50**

- Amplifiers connected to an HDMI terminal ignore this setting.

## Reset

Restores the settings of "Sound" to the initial.

## Setup

### Menu Language

You can choose the language used for on-screen messages.

- **English (EU) / Deutsch / Français(UE) / Italiano / Español (UE) / Català / Nederlands / Dansk / Svenska / Norsk / Suomi / Polski / Magyar / Русский / Ελληνικά / Português / Český / Български / Українська / Türkçe / Română / العربية / 繁體中文 / 中文 / فارسی / Bahasa Melayu / ไทย / Español (US) / Français(US) / English (US) / 日本語**

### Front Panel Lock

Makes operations through the buttons on the monitor ineffective.

- **On** : Making the buttons on the monitor ineffective.
- **Off** : Making the buttons on the monitor effective.
  - You can turn on/off the power by pressing and holding the [⏻] button on the monitor for more than 3 seconds even when the setting is "On".
  - You can change the setting to "Off" by pressing and holding the [MENU] button on the monitor for more than 3 seconds.
  - The settings returns to "Off" after disconnecting the power cord.

### Auto Shut Off

Turns off the monitor automatically when no signal comes in.

- **On** : Turns off the monitor automatically when no signal comes in for 10 minutes or no operation is done for 4 hours.
- **Off** : Deactivates the function.



# Aspect

Adjusts the aspect of pictures.

- The setting is also adjustable through the [ASPECT] button on the remote control.

## ◆ Options when the current input signal is SD

- **Auto** : When the video signal contains information about aspect ratio (WSS etc.), the aspect is switched accordingly. In other cases, the picture is displayed in either "Regular" or "Panoramic", depending on the setting of "4:3 Aspect Setting" (→ page 31).

- **Regular** : No modifying of aspect. Black areas remain at the left and right side of the picture.

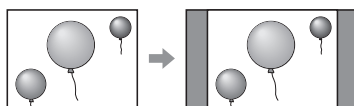

- **Panoramic** : Zooming a picture to the width of the monitor without unnatural deformation.

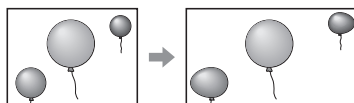

- **14:9 Zoom** : Zooming a 14:9-aspect picture in the way that the upper and lower black bands are edged out. Black areas remain at the left and right side of the picture.

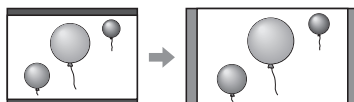

- You cannot select "14:9 Zoom" for signals in 480i and 480p.

- **16:9 Zoom** : Zooming a picture in the way that the upper and lower black bands in a cinema program are edged out.

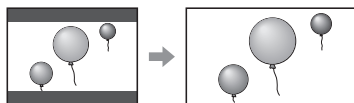

- **16:9 Zoom Subtitle** : Zooming a picture in the way that the upper and lower black bands of a cinema program are edged out leaving space for captions.

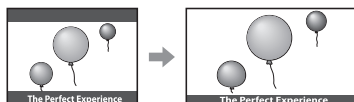

- **Full** : Stretching a picture to the width of the monitor.

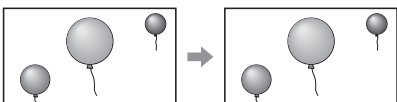

## ◆ Options when the current input signal is HD

- You can select "Full Native" only when the input signal is 1080i/p.

- **Full** : Stretching a picture to the width of the monitor.

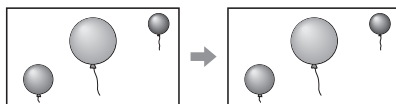

- **Full Native** : Displaying a picture of 1080i/p without enlargement.

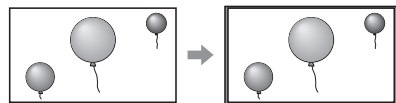

- **Slim** : Shrinking a picture horizontally. Black areas remain at the left and right side of the picture.

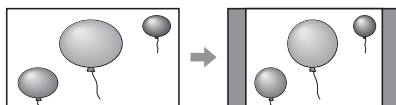

- **Panoramic Zoom** : Zooming a picture without unnatural deformation in the way to edge out the black parts around a 4:3-aspect cinema program transferred through 16:9-aspect signal.

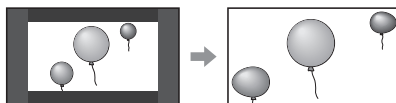

## ◆ Options when the current input signal is from a PC

- You cannot select "Just" and "1:1" for some input signals.

- **Full** : Stretching a picture to the width of the monitor.

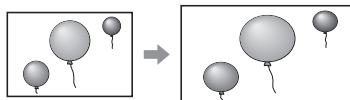

- **Just** : No modifying of aspect. Black areas remain at the left and right side of the picture.

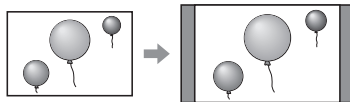

- **1:1** : No modifying of aspect or resolution. Black areas remain around the picture.

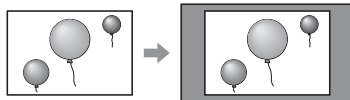



## Position Adjustment

Adjusts the picture position on the monitor.

- Vertical adjustment is effective when “Aspect” is set to “14:9 Zoom”, “16:9 Zoom”, “Panoramic”, “16:9 Zoom Subtitle”, or “Panoramic Zoom”.
- Horizontal adjustment is effective only when “Aspect” is set to “Panoramic Zoom”.
- When a PC signal is input, adjust the position on “PC Position Adjustment” in “PC Setting”.
- The positioning is reset as the power is turned off.
- The positioning is reset as the signal format changes.
- The positioning is reset as the signal aspect changes.

## Power Indicator

Sets the action of the power indicator.

- **On** : The power indicator remains lit while the power is on.
- **Off** : The power indicator does not light.
- The power indicator lights regardless of this setting if no signal is input while the power is on.

## Display

Displays the source indication.

- **On / Off**
- The source indication appears regardless of this setting if no signal is input.
- The source indication is displayed for 4 seconds after changing the source even if the setting is “Off”.

## Input Label

Adds a source name specifying a device after the source name ("Input-1" - "Input-3").

- **(No label) / VCR / DVD / Blu-ray Disc / PVR / D-VHS / STB / SAT / AMP / GAME / CAM / DISC / PC**

## 4:3 Aspect Setting

Selects the aspect setting which is applied when "Aspect" (→ page 28) is set to "Auto". The picture is displayed in the selected aspect when the aspect is 4:3 or when the monitor cannot detect the aspect of a picture.

- **Regular** : Displays the picture in "Regular".
- **Panoramic** : Displays the picture in "Panoramic".

## 1080 Auto Setting

Selects the default aspect for 1080i/p signals.

- **Full** : Expands the picture to the full display size.
- **Full Native** : Displays the picture in the same magnification (100% scan).

## Input-3 Setting

Selects the signal type for the INPUT-3 terminal (D-sub 15 pin).

- Use the supplied conversion cables and other cords according to the type of connection. (→ page 06)
- **PC** : For PC signals
- **Component** : For component signals
- **Composite** : For composite signals



## PC Setting

Adjusts the settings for PC signals.

- The items below are unadjustable when no PC signal is input: "H Size", "V Size", "Dot Clock", "Clock Phase", "PC Position Adjustment", and "Auto Position Adjustment".
- "Auto Position Adjustment" is unavailable for INPUT-3.
- "Dot Clock" and "Clock Phase" are unavailable for INPUT-1, INPUT-2.

### ◆ Sampling Mode

Sets the display size for an analog input signal.

- **Std** : For VGA60 and XGA60 signals
- **Wide** : For WVGA60, WXGA (1280), WXGA (1360) and WXGA60 signals

### ◆ WXGA Select

Sets the display size for an analog input signal.

- **1280\*768** : For WXGA (1280) signal
- **1360\*768** : For WXGA (1360) signal
- **1366\*768** : For WXGA60 signal

### ◆ SXGA / SXGA+

Sets the display size for an analog input signal.

- **SXGA** : For SXGA60 signal
- **SXGA+** : For SXGA+60 signal

### ◆ H Size

Adjusts the picture width.

- **-20 - +20** (Smaller ↔ Larger)

### ◆ V Size

Adjusts the picture height.

- **-20 - +20** (Smaller ↔ Larger)



### ◆ **Dot Clock**

Adjust this when the picture is not aligned vertically.

- The adjustment is kept after turning off the power.

■ **-20 - +20**

### ◆ **Clock Phase**

Adjust this when letters on the screen look blurred or swaying.

- The adjustment is kept after turning off the power.

■ **0 - 31**

### ◆ **PC Position Adjustment**

Adjusts the picture position on the monitor.

- The adjustment is kept after turning off the power.

### ◆ **Auto Position Adjustment**

Adjusts the picture position automatically.

### ◆ **Reset**

Restores the settings of "PC Setting" to the initial.

## Reset

Restores the settings of "Setup" to the initial.

# HDMI

## Control with HDMI

Makes an HDMI CEC-compatible external component controllable through this monitor.

- **On** : Enables HDMI CEC control.
- **Off** : Deactivates HDMI CEC control.

## One Touch Play

Starting playback on an HDMI CEC-compatible external component automatically turns on the monitor and change its source to the component.

- The setting is fixed to "Off" and unadjustable when "Control with HDMI" is set to "Off".
- Dedicated HDMI components cooperate with the monitor regardless of the setting.
- **On / Off**

## Power Off Link

Turning off the monitor automatically turns off an HDMI CEC-compatible external component.

- The setting is fixed to "Off" and unadjustable when "Control with HDMI" is set to "Off".
- Dedicated HDMI components cooperate with the monitor regardless of the setting.
- **On / Off**

## AMP Control

Makes an HDMI CEC-compatible amplifier controllable through the monitor.

- The setting is fixed to "Off" and unadjustable when "Control with HDMI" is set to "Off".
- **On / Off**

## Input-1 Audio

Selects the audio signal type for INPUT-1.

- **Auto** : Detects the type automatically.
- **Digital** : For HDMI equipment.
- **Analogue** : For DVI equipment.

## Reset

Restores the settings of "HDMI" to the initial.



# Viewing photographs on SD card/USB device

## Cautions

- Insert or remove SD cards and USB devices gently and in the right direction. Otherwise, the devices or the monitor may be damaged.
- It is recommended to keep a backup of your files.
- Do not connect a mouse, keyboard or the like.
- Do not use a USB hub or extension cable.

## 1 Insert an SD card/USB device into the SD card slot/USB terminal on the side of the monitor.

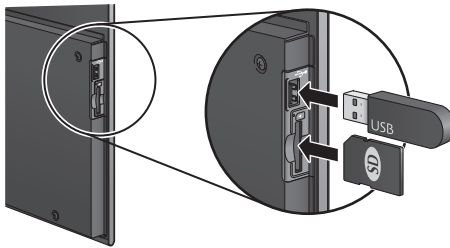

- Slide the SD card into the slot until it clicks into place.
- To remove the SD card, push it in until it clicks and then pull it out.

## 2 Set the input to "Input-4".

The Folder Index shows a list of folders and photographs on the device .

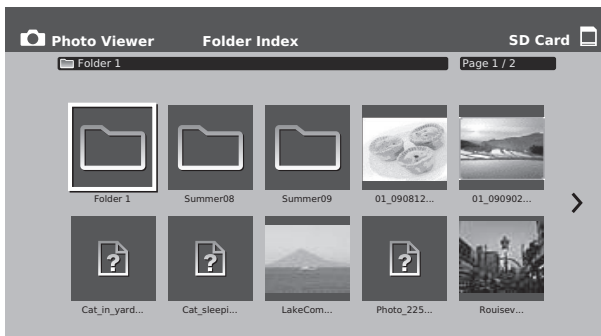

- To view the next/previous page, press [GREEN]/[RED].
- When you turn on the monitor while both an SD card and a USB device are connected, the photographs on the SD card are displayed. Select “Flash Device” in the “Device” setting (→ page 38) to display the photographs on the USB device.
- The thumbnails of some files may not be shown.
- This monitor can only display file names as alphabetical letters.
- Photographs with large file-sizes may take a while to be displayed.

### 3 Select a photograph to display, and press [OK].

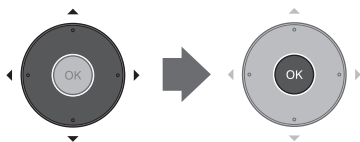

The selected photograph is displayed full-screen.

- Some files may be displayed with bands around the edges.
- To show the photographs in a folder, press [OK] on the folder.
- To see the next/previous photograph, press [▶]/[◀].
- To exit the full-screen display and show the Folder Index, press [EXIT].

#### To exit the photograph display

Select an input other than “Input-4”.

## To view photographs in slide show

### 1 Press [YELLOW] in the Folder Index.

YELLOW



- The slide show starts from the selected photograph.
- To pause/resume the slide show, press [OK].
- To display the photographs in a random order, press [BLUE] in the Folder Index.
- To finish the slide show, press [BACK].



# To customize the settings

## 1 Open the menu.

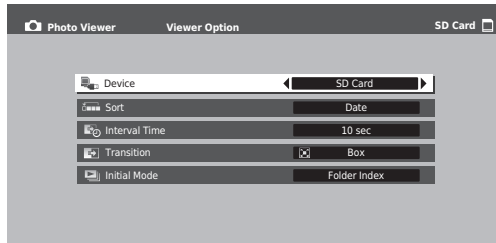

## 2 Change the settings.

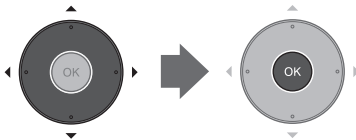

## 3 Exit the menu.



### ◆ Device

Select which device is displayed when both are connected; SD card or USB device.

### ◆ Sort

Select the display order of photographs.

- **File Name** : In alphabetic order by file name.
- **Date** : In order of the date when the file was modified.

### ◆ Interval Time

Select how long each picture is displayed for during slide shows.

### ◆ Transition

Select the transition effect used during slide shows.

### ◆ Initial Mode

Select the initial mode of the Photo viewer function. Either the Folder Index is displayed, or a slide show is started automatically.

- Menu items are displayed in English if you have selected “中文”, “繁體中文” or “ไทย”, “العربية”, “فارسی” in “Menu Language” of “Setup”.

## About SD cards and USB devices

- The maximum capacity of devices playable on this monitor is as follows:
  - SD cards, miniSD cards, microSD cards: 2 GB
  - SDHC cards, miniSDHC cards, microSDHC cards: 32 GB
  - USB devices: 32 GB
- When using miniSD cards or microSD cards, put them in an appropriate adapter before inserting them into the monitor.
- Use SD cards which are guaranteed to work between  $-25^{\circ}\text{C}$  and  $85^{\circ}\text{C}$ .
- Not all SD cards or USB devices are guaranteed to work on this monitor.
- Format SD cards on a photographing device such as a digital camera, or on a computer using SD memory card formatting software.
- Format USB devices on a computer in "FAT 32" or "FAT".

## Playable files

- Format: JPEG (.jpg, .JPG)
- Pixel size: 160 x 120 – 8192 x 8192 (The file size must be under 10 MB.)
- Picture files of other than JPEG format, Progressive JPEG files, JPEG 2000 files, MOTION JPEG files or music files cannot be played back.

## About the displaying of pictures

- Filenames which are too long may be shortened when displayed.
- If you have edited or copied picture files on a computer, their date properties may have been modified, and their thumbnail may have been deleted.
- Some picture files may not be displayed properly due to the device which created them.
- It may take some time before pictures are displayed when the device contains a large number of files or folders.
- This monitor can display up to 9,999 files.
- Pictures in a folder deeper than the eighth layer of subfolders may not be displayed.
- When selecting a file of a format which is not supported, its thumbnail may be displayed instead.
- Picture quality can be adjusted using the items in the "Picture" menu. However, some of them are not available for the Photo viewer.
- If the screen as illustrated on the right is displayed, the Photo viewer is starting up. Wait for a while until it is ready.

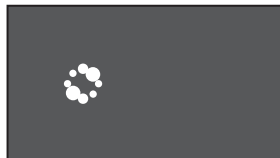

# External Control

You can control GD-32X1U from external control equipment (a personal computer or a dedicated controller) via the RS-232C terminal on the rear of the monitor.

- Connect the RS-232C extension cable to the RS-232C terminal on the rear side of the monitor. (→ page 07)

## Communication specifications

### Cable

A crossover cable with a RS-232C connector

### Communication specifications

- Baud Rate: 19200 bps
- Data Bits: 8 bits
- Parity: Odd parity
- Stop Bits: 1 bit
- Flow Control: No control
- Communication Code: ASCII Code

### Terminal specifications

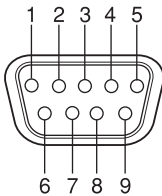

This is a male terminal.

Pin No.	Signal
1	—
2	RXD
3	TXD
4	—
5	GND
6	—
7	—
8	—
9	—

## Command outline

To control the monitor from external control equipment, send operation commands to the monitor.

### Example of communication procedures

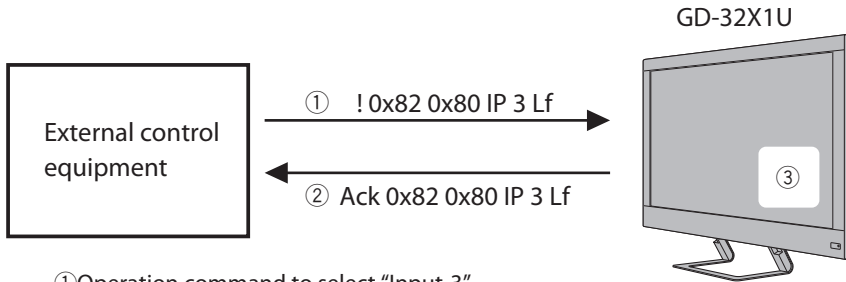

- ① Operation command to select "Input-3".
- ② Acknowledgment from the monitor.
- ③ The input is changed to "Input-3".

### Command structure

**! 0x82 0x80 IP 3 Lf**

a      b                  c                  d      e      f

a: Header	! : Operation command from the external control device. ? : Enquiry command from the external control device. @ : Response from the monitor to an enquiry command. Ack (0x06): Positive acknowledge from the monitor. Nak (0x15): Negative acknowledge from the monitor.
b: Device ID	0x82 (fixed)
c: Monitor ID	0x80 – 0xFF (Default setting is 0x80.)
d: Command	See "Command list" on the next page.
e: Data	
f: Termination	Lf (0x0A)

## Command list

- “\*” is the monitor ID. Normally, set it to “0x80”.
- Enter the appropriate data to “xx” or “x”.

No.	Operation commands									
1†	!	0x82	*	P	W	x	Lf			
2†	!	0x82	*	I	P	x	Lf			
3†	!	0x82	*	V	L	x	x	Lf		
4†	!	0x82	*	A	M	x	Lf			
5†	!	0x82	*	V	S	x	Lf			
6†	!	0x82	*	A	S	x	Lf			
7	!	0x82	*	R	C	x	x	x	x	Lf
8	!	0x82	*	S	U	I	C	x	x	Lf
9	!	0x82	*	S	U	R	M	x	Lf	
10††	!	0x82	*	S	U	F	K	x	Lf	

† For these commands, you can make enquiry commands by entering “?” instead of “!” and omitting the data bytes. When you send an enquiry command, the monitor sends back an acknowledge, then an answer about its current status.

†† When you change this setting, setting of “Front Panel Lock” (→ page 27) is also changed accordingly.

Functions	Data
Turns on/off the monitor.	0: Off 1: On +: Switches the power status.
Selects the input.	1: Input-1 2: Input-2 3: Input-3 4: Input-4
Adjusts the volume.	00 – 50: Sets the volume directly. +: Turns the volume up. –: Turns the volume down.
Turns muting on/off.	0: Mute is released. 1: The sound is muted. +: Switches the mute status.
Selects an item of “Memory Setting” (→ page 13).	0: Memory1 / 1: Memory2 / 2: Memory3 / 3: Memory4 / 4: Memory5 / 5: Memory6 / +, –: Changes the setting.
Selects the aspect ratio.	0: Panoramic, Panoramic Zoom / 1: 16:9 Zoom / 2: Full / 3: Regular, Slim / 4: Full Native / 5: 14:9 Zoom / 6: 16:9 Zoom Subtitle / 7: Just / 8: 1:1 / 9: Auto / +, –: Changes the aspect ratio setting.
Sends the remote control code pass-through.	0x0000 – 0xFFFF
Sets the monitor ID.	0x80 – 0xFF
Enables/disables operations from the remote control.	0: Disabled. 1: Enabled.
Enables/disables operations from the touch sensor panel.	0: Disabled. 1: Enabled.

# Troubleshooting

## **The following are not malfunctions.**

- This LCD display is built with very high precision technology; however, be aware that a few pixels may be missing or constantly lit.
- When a still image is displayed for a long time, it may remain indistinctly on the screen after the picture has changed. The remaining picture will disappear after a while.
- The following symptoms are problems only when pictures or sounds are not played back normally.
  - A slight electric shock occurs when you touch the monitor.
  - The top and/or rear panel of the monitor becomes hot.
  - The monitor emits a cracking noise.
  - The monitor emits a mechanical noise.
- If the monitor does not operate normally, perform the following to reset the monitor.
  - Unplug the monitor from the wall outlet, and plug it in again.

## **Cannot turn on the monitor.**

- Connect the power cord properly. (→ page 08)

## **The remote control does not work.**

- Insert the batteries in the correct direction. (→ page 04)
- Replace the batteries with new ones.
- Aim the remote control to the remote sensor on the monitor.  
(→ page 09)
  - The effective range of the remote control is about 7 meters (23 feet).
- Get closer to the monitor.
- Remove any obstruction between the remote control and the monitor.

## **No picture from a connected device.**

- Select the correct input on the monitor.
- Connect the external device properly.
- Turn on the external device and start playback.

## **The monitor turns off automatically.**

- When you want to display a picture on the monitor for a long time, select "Off" for "Auto Shut Off" (→ page 27) in "Setup".

**No sound.**

- No sound is output from the monitor if the dedicated speaker unit (sold separately) is not connected. (→ page 05)
- Press the MUTING button.
- Check the amplifier connection.
  - When “AMP” is selected under “Speaker”, the sound is output from the amplifier, and not from the speakers of the monitor. (→ page 11)

**No picture from HDMI devices.**

- Select the correct input on the monitor.
- Use a cable marked with the HDMI logo.
- Please use a High Speed HDMI™ Cable. High Speed HDMI™ Cables are tested to carry an HD signal up to 1080p and higher. (→ page 07)

**No sound from HDMI devices.**

- Set “Input-1 Audio” properly. (→ page 35)

**Cannot control HDMI CEC devices.**

- Set “Control with HDMI” to “On”. (→ page 34)
- Some devices may not accept controls by HDMI CEC.

**Cannot operate the product using the buttons on the monitor.**

- Set “Front Panel Lock” to “Off”. (→ page 27)

**Picture from a computer is strange.**

- Adjust the items under “PC Setting”. (→ page 32)

**The source indication stays on the display.**

- Turn on the selected external device and start playback.
  - When no signal is input, you cannot turn off the source indication.

**The picture and the sound do not synchronize.**

- Adjust “Lip Sync”. (→ page 25)
- Adjust “Picture Delay Time”. (→ page 23)

**Colors are strange.**

- Adjust the items under “Picture”. (→ page A-2)
- Load one of the picture presets to discard the current settings and apply the selected preset. (→ page A-3)

**No pictures displayed from an SD card/USB device.**

- Check whether the picture files are of the supported format. (→ page 39)



# Specifications

Model name	GD-32X1U
LCD panel	32-inch (viewable)
Screen size (visible area size measured diagonally)	801.3 mm (31.5")
Display resolution	1920×1080
Display colors	1.07 billion colors (10 bit color)
Viewing angle (TYP.)	178 ° (Horizontally) 178 ° (Vertically)
Luminance (TYP.)	400 cd/m <sup>2</sup>
Contrast ratio (TYP.)	4000 : 1
Horizontal/vertical frequency (computer signal)	Horizontal: 24.83 kHz – 67.5 kHz Vertical: 56.42 Hz – 75 Hz
Compliant video signal formats	→ page 50
Audio output	Speakers: 5 W + 5 W (When TS-C32SPG (12 Ω : sold separately) is connected.)
Operating environment	Operating temperature: 0 °C – 40 °C (32 °F – 104 °F) Operating humidity: 20 % – 80 % (non-condensing) (Slightly variable depending on ambient conditions for installation.)
Power requirements	DC 28V
AC adapter (FSP180-AKAN1)	AC 100 V - 240V, 50 Hz/60 Hz
Power consumption	136 W
Power consumption (on standby)	AC 230 V: 0.55 W AC 120 V: 0.67 W
Dimensions	→ page 48
Mass	5.7 kg (12.6 lbs) (without the stand) 6.9 kg (15.2 lbs) (including the stand) 6.4 kg (14.1 lbs) (including the VESA bracket)

Supplied accessories	→ page 04
Input terminals	HDMI ×2, D-sub (15 pin) ×1, Audio input (3.5 mm stereo mini jack), USB type slot, SD card slot
Output terminals	Speaker output for the exclusive speaker unit
External control	RS-232C-compliant

### Display Calibration

When you want to calibrate the gamma and the white balance of the monitor, you can download a dedicated software from the web page below.

<http://www.jvc-victor.co.jp/english/download/gd-32x1/>

- To perform the calibration, you need i1Display 2 of X-Rite Incorporated and a Windows PC.

### Notice on transportation

- This monitor is precision equipment and needs dedicated packing material for transportation. Never use any packing material supplied from sources other than JVC or JVC-authorized dealers.

# Dimensions

unit: mm (inch)

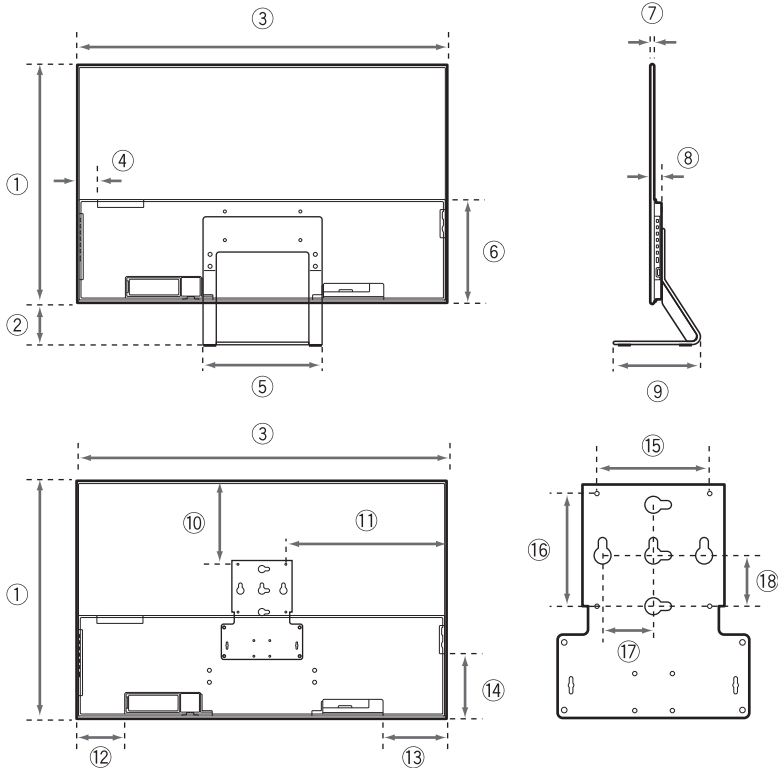

① : 496.1 (19 5/8)	⑦ : 7.8 (3/8)	⑭ : 136.0 (5 3/8)
② : 55.0 (2 1/4)	⑧ : 22.5 (1)	⑮ : 100.0 (4)
/80.0 (3 1/4)(with TS-C32SPG)	⑨ : 190.9 (7 5/8)	⑯ : 100.0 (4)
③ : 772.4 (30 1/2)	⑩ : 173.7 (6 7/8)	⑰ : 45.0 (1 7/8)
④ : 40.7 (1 5/8)	⑪ : 336.2 (13 1/4)	⑱ : 45.0 (1 7/8)
⑤ : 254.0 (10)	⑫ : 99.8 (4)	
⑥ : 214.7 (8 1/2)	⑬ : 133.7 (5 3/8)	

- Use screws of adequate length (M4 × 12 – 16) to fix the VESA bracket and wall mount adapter.

## Logos & Licenses



As an “ENERGY STAR®” partner, JVC has determined that this product or product model meets the “ENERGY STAR®” guidelines for energy efficiency.

- For easy understanding, pictures and illustrations are shown by being emphasized, omitted or composed, and may slightly be different from actual products.
- Design and specifications are subject to change without notice.
- HDMI, the HDMI Logo and High-Definition Multimedia Interface are trademarks or registered trademarks of HDMI Licensing LLC.
- “x.v.Color” and “x.v.Color” logo are trademarks.
- All company names and product names mentioned herein are used for identification purposes only, and may be the trademarks or registered trademarks of their respective companies.

# Compliant signal formats (1)

## INPUT-3 terminal (PC)

Signal	Frequency		
	Vertical (Hz)	Horizontal (kHz)	Dot clock (MHz)
PC98	56.42	24.823	21.050
VGA 60 <sup>†1</sup>	59.94	31.469	25.175
VGA 72	72.81	37.861	31.500
VGA 75	75.00	37.500	31.500
WVGA 60 <sup>†2</sup>	60.00	31.020	33.750
SVGA 60	60.32	37.879	40.000
SVGA 72	72.19	48.077	50.000
SVGA 75	75.00	46.875	49.500
XGA 60 <sup>†1</sup>	60.00	48.363	65.000
XGA 70	70.07	56.476	75.000
XGA 75	75.03	60.023	78.750
WXGA(1280) <sup>†2†3</sup>	59.87	47.776	79.500
WXGA(1360) <sup>†2†4</sup>	60.02	47.712	85.500
WXGA 60 <sup>†2†5</sup>	60.00	48.363	86.715
SXGA 60 <sup>†6</sup>	60.02	63.981	108.000
SXGA+ 60 <sup>†7</sup>	60.02	63.981	108.000
SXGA+ 60*	60.00	65.220	122.614
1280x720	60.00	45.000	74.250
1920x1080	60.00	67.500	148.500

†1 : Set "Sampling Mode" to "Std".

†2 : Set "Sampling Mode" to "Wide".

†3 : Set "WXGA Select" to "1280\*768".

†4 : Set "WXGA Select" to "1360\*768".

†5 : Set "WXGA Select" to "1366\*768".

†6 : Set "SXGA / SXGA+" to "SXGA".

†7 : Set "SXGA / SXGA+" to "SXGA+".

	Total pixels		Effective pixels		Standard
	pixel per line	line per frame	pixel per line	line per frame	
	848	440	640	400	—
	800	525	640	480	VESA Standard
	832	520	640	480	VESA Standard
	840	500	640	480	VESA Standard
	1088	517	848	480	—
	1056	628	800	600	VESA Standard
	1040	666	800	600	VESA Standard
	1056	625	800	600	VESA Standard
	1344	806	1024	768	VESA Standard
	1328	806	1024	768	VESA Standard
	1312	800	1024	768	VESA Standard
	1664	798	1280	768	—
	1792	795	1360	768	VESA Standard
	1793	806	1366	768	—
	1688	1066	1280	1024	VESA Standard
	1688	1066	1400	1050	—
	1880	1087	1400	1050	—
	1650	750	1280	720	—
	2200	1125	1920	1080	EIA/CEA-861-D

- Signals in a format not listed above may not be displayed properly. Change the resolution setting on the PC.
- Some signals may not be displayed properly even if their format is in the list above.
- Because signals in PC98, VGA 72, VGA 75, SVGA 72, SVGA 75, XGA 70 and XGA 75 need to be converted into 60Hz before displayed on the monitor, playback of these signals look jerky. Select other signal formats for smoother playback of moving pictures.

## Compliant signal formats (2)

### INPUT-3 terminal (composite)

Signal	Frequency	
	Vertical (Hz)	Horizontal (kHz)
PAL/50	50.00	15.63
PAL/60	59.94	15.73
SECAM	50.00	15.63
NTSC3.58	59.94	15.73
NTSC4.43	59.94	15.73
PAL M	59.94	15.73
PAL N	50.00	15.63

### INPUT-3 terminal (component)

Signal	Frequency	
	Vertical (Hz)	Horizontal (kHz)
480/60i	59.94	15.73
576/50i	50.00	15.63
480/60p	59.94	31.47
576/50p	50.00	31.25
720/60p	59.94	44.96
720/50p	50.00	37.50
1080/60i	59.94	33.72
1080/50i	50.00	28.13
1080/60p	59.94	67.43
1080/50p	50.00	56.25
1080/30p	29.97	33.72
1080/24p	24.00	27.00

### INPUT-1, INPUT-2 terminal (HDMI-HDMI)

Signal	Frequency		
	Vertical (Hz)	Horizontal (kHz)	Dot clock (MHz)
VGA 60	59.94/60	31.469/31.5	25.175/25.2
480/60p	59.94/60	31.469/31.5	27/27.027
720/60p	59.94/60	44.955/45	74.176/74.25
1080/60i	59.94/60	33.716/33.75	74.176/74.25
480/60i	59.94/60	15.734/17.75	27/27.027
1080/60p*	59.94/60	67.433/67.5	148.352/148.5
576/50p	50.000	31.25	27
720/50p	50.000	37.5	74.25
1080/50i	50.000	28.13	74.25
576/50i	50.000	15.63	27
1080/50p	50.000	56.25	148.5
1080/24p	23.976/24	26.973/27	74.176/74.25
1080/25p	25.000	28.13	74.25
1080/30p	29.97/30	33.716/33.75	74.176/74.25

	Total pixels		Effective pixels	
	pixel per line	line per frame	pixel per line	line per frame
	800	525	640	480
	858	525	720	480
	1650	750	1280	720
	2200	562/563	1920	1080
	858	262/263	720	480
	2200	1125	1920	1080
	864	625	720	576
	1980	750	1280	720
	2640	562/563	1920	1080
	864	312/313	720	576
	2640	1125	1920	1080
	2750	1125	1920	1080
	2640	1125	1920	1080
	2200	1125	1920	1080

\* EIA/CEA-861-D-compliant

- Signals in a format not listed above may not be displayed properly. Change the resolution setting on the PC.
- Some signals may not be displayed properly even if their format is in the list above.



- This software is based in part on the work of the Independent JPEG Group.
- The open source software is embedded in this product. For more information, please go to:  
[http://www.jvc-victor.co.jp/download/lnx/09jvc\\_mo/index.html](http://www.jvc-victor.co.jp/download/lnx/09jvc_mo/index.html)
- DejaVu font is used in this product under the license below.

---

Fonts are (c) Bitstream (see below). DejaVu changes are in public domain. Glyphs imported from Arev fonts are (c) Tavmjong Bah (see below)

#### Bitstream Vera Fonts Copyright

-----  
Copyright (c) 2003 by Bitstream, Inc. All Rights Reserved. Bitstream Vera is a trademark of Bitstream, Inc.

Permission is hereby granted, free of charge, to any person obtaining a copy of the fonts accompanying this license ("Fonts") and associated documentation files (the "Font Software"), to reproduce and distribute the Font Software, including without limitation the rights to use, copy, merge, publish, distribute, and/or sell copies of the Font Software, and to permit persons to whom the Font Software is furnished to do so, subject to the following conditions:

The above copyright and trademark notices and this permission notice shall be included in all copies of one or more of the Font Software typefaces.

The Font Software may be modified, altered, or added to, and in particular the designs of glyphs or characters in the Fonts may be modified and additional glyphs or characters may be added to the Fonts, only if the fonts are renamed to names not containing either the words "Bitstream" or the word "Vera".

This License becomes null and void to the extent applicable to Fonts or Font Software that has been modified and is distributed under the "Bitstream Vera" names.

The Font Software may be sold as part of a larger software package but no copy of one or more of the Font Software typefaces may be sold by itself.

THE FONT SOFTWARE IS PROVIDED "AS IS", WITHOUT WARRANTY OF ANY KIND, EXPRESS OR IMPLIED, INCLUDING BUT NOT LIMITED TO ANY WARRANTIES OF MERCHANTABILITY, FITNESS FOR A PARTICULAR PURPOSE AND NONINFRINGEMENT OF COPYRIGHT, PATENT, TRADEMARK, OR OTHER RIGHT. IN NO EVENT SHALL BITSTREAM OR THE GNOME FOUNDATION BE LIABLE FOR ANY CLAIM, DAMAGES OR OTHER LIABILITY, INCLUDING ANY GENERAL, SPECIAL, INDIRECT, INCIDENTAL, OR CONSEQUENTIAL DAMAGES, WHETHER IN AN ACTION OF CONTRACT, TORT OR OTHERWISE, ARISING FROM, OUT OF THE USE OR INABILITY TO USE THE FONT SOFTWARE OR FROM OTHER DEALINGS IN THE FONT SOFTWARE.

Except as contained in this notice, the names of Gnome, the Gnome Foundation, and Bitstream Inc., shall not be used in advertising or otherwise to promote the sale, use or other dealings in this Font Software without prior written authorization from the Gnome Foundation or Bitstream Inc., respectively. For further information, contact: fonts at gnome dot org.

## Arev Fonts Copyright

---

Copyright (c) 2006 by Tavmjong Bah. All Rights Reserved.

Permission is hereby granted, free of charge, to any person obtaining a copy of the fonts accompanying this license ("Fonts") and associated documentation files (the "Font Software"), to reproduce and distribute the modifications to the Bitstream Vera Font Software, including without limitation the rights to use, copy, merge, publish, distribute, and/or sell copies of the Font Software, and to permit persons to whom the Font Software is furnished to do so, subject to the following conditions:

The above copyright and trademark notices and this permission notice shall be included in all copies of one or more of the Font Software typefaces.

The Font Software may be modified, altered, or added to, and in particular the designs of glyphs or characters in the Fonts may be modified and additional glyphs or characters may be added to the Fonts, only if the fonts are renamed to names not containing either the words "Tavmjong Bah" or the word "Arev".

This License becomes null and void to the extent applicable to Fonts or Font Software that has been modified and is distributed under the "Tavmjong Bah Arev" names.

The Font Software may be sold as part of a larger software package but no copy of one or more of the Font Software typefaces may be sold by itself.

THE FONT SOFTWARE IS PROVIDED "AS IS", WITHOUT WARRANTY OF ANY KIND, EXPRESS OR IMPLIED, INCLUDING BUT NOT LIMITED TO ANY WARRANTIES OF MERCHANTABILITY, FITNESS FOR A PARTICULAR PURPOSE AND NONINFRINGEMENT OF COPYRIGHT, PATENT, TRADEMARK, OR OTHER RIGHT. IN NO EVENT SHALL TAVMJONG BAH BE LIABLE FOR ANY CLAIM, DAMAGES OR OTHER LIABILITY, INCLUDING ANY GENERAL, SPECIAL, INDIRECT, INCIDENTAL, OR CONSEQUENTIAL DAMAGES, WHETHER IN AN ACTION OF CONTRACT, TORT OR OTHERWISE, ARISING FROM, OUT OF THE USE OR INABILITY TO USE THE FONT SOFTWARE OR FROM OTHER DEALINGS IN THE FONT SOFTWARE.

Except as contained in this notice, the name of Tavmjong Bah shall not be used in advertising or otherwise to promote the sale, use or other dealings in this Font Software without prior written authorization from Tavmjong Bah. For further information, contact: [tavmjong@free.fr](mailto:tavmjong@free.fr).

§Id: LICENSE 2133 2007-11-28 02:46:28Z lechimp §

# Index

## Icons

▲▼◀▶..... 10

## Numbers

3DY/C ..... 22

4:3 Aspect Setting..... 31

1080 Auto Setting..... 31

## A

AMP Control ..... 35

Aspect..... 28

ASPECT ..... 10

Auto Shut Off ..... 27

Auto Volume Control..... 25

## B

Backlight ..... 16

Backlight Setting..... 17

Balance..... 25

Bass ..... 25

Battery..... 04

Brightness ..... 15

## C

Color ..... 14

Color Management ..... 20

Color Matrix..... 18

Color Mngmt. Setting ..... 20

Color Space ..... 18

Color System..... 17

Color Temperature ..... 19

Component..... 06

Composite..... 06

Computer..... 06, A-10

Connection ..... 06

Contrast ..... 15

Contrast Setting..... 15

Control with HDMI ..... 34

## D

Digital camera ..... A-11

Display ..... 30

DVI ..... 06

Dynamic Gamma..... 21

## E

Eco Mode ..... 24

Enhancer ..... 16

Enhancer Setting..... 16

EXIT ..... 12

## F

Front Panel Lock ..... 27

## G

Gamma..... 21

## H

HDMI ..... 34

HDMI CEC..... 11

## I

Input-1 Audio..... 35

Input-3 Setting..... 31

Input Label ..... 31

- L**
- LINK ..... 11
  - Lip Sync ..... 25
- M**
- Main unit ..... 09
  - MENU ..... 12
  - Menu Language ..... 27
  - MUTING ..... 10
- N**
- Natural Cinema ..... 23
  - Noise Reduction ..... 22
- O**
- One Touch Play ..... 34
  - OPTION ..... 10
  - Other ..... 24
- P**
- PC Monitor Mode ..... 23
  - PC Setting ..... 32
  - PEQ ..... 26
  - Picture ..... A-2, 13
  - Picture Delay Time ..... 23
  - Position Adjustment ..... 30
  - POWER ..... 10
  - Power cable ..... 08
  - Power indicator ..... 09
  - Power Indicator ..... 30
  - Power Off Link ..... 34
- R**
- Remote control unit ..... 10
  - Remote sensor ..... 09
  - Reset ..... 26, 33, 35
  - RS-232C ..... 40
- S**
- Setup ..... 27
  - Sharpness ..... 16
  - Sound ..... 25
  - Speaker unit ..... 05
- T**
- Tint ..... 14
  - Tint Setting ..... 14
  - Treble ..... 25
  - Turn On Volume ..... 26
- V**
- Video game ..... A-5
  - VOL +/- ..... 10
  - Volume Limit ..... 26
- W**
- White Balance Setting ..... 19

**JVC**

**JVC**

**LCD Monitor**



**GD-32X1U**

**JVC**